

## LIA Series

**Exposed Linear Encoder  
with Signal Control**

## Features

Encoders that report the position in drive systems, especially in linear drives, are often presented with contradictory demands, such as high resolution, high accuracy, compact size, low mass, and fast measuring speed.

- High path resolutions within the controller are necessary to achieve the high servo amplification required by highly-dynamic digital drives that can follow the finest contours without oscillations.
- The graduated scale is definitive for the quality of a linear encoder. Requirements for maximum position deviations of  $\pm 2 \mu\text{m}$  per meter or less are no rarity. The emphasis is mostly on the avoidance of short-range errors, since long-range errors, mostly linear error components, can often be compensated.
- The concentration of multiple axes in motion in very tight spaces, such as in semiconductor-producing machines, requires the miniaturization of the drives, guideways and encoders.
- High machining speeds and therefore high accelerations make low masses of the components in motion essential.

### Other features are:

- Reference signal(s) with repeatability accurate to a specific increment, regardless of the direction from which the reference mark(s) is/are traversed
- Optional, additional optical switching sensor(s) integrated in the scanning head (LIA 21; LIA 22)
- Compact size
- Large mounting tolerances

The LIA encoders from **NUMERIK JENA** are equipped with features that fulfill these high requirements in an ideal manner.

Therefore, encoders are available for a broad range of applications.

- The new interpolation circuitry, with subdivision factors of up to 100, is integrated in the 15-pin D-sub connector or in the scanning head, and makes **resolutions down to  $0.05 \mu\text{m}$**  possible without any additional electronics.
- The permissible **traversing speed** was raised to 10 m/s for sinusoidal signal output, and to 1.6 m/s for square wave signal output, with a resolution of  $0.1 \mu\text{m}$ .
- The short-range position errors (interpolation errors) were significantly reduced by introducing an electronic **compensation of amplitude and offset deviations** of the coarse signals. This compensation functions without following error in all velocity ranges. Such deviations are caused by mounting errors and scale contamination, for example.
- The physical mounting is made easier by use of an **LED**, whose brightness gives information about the adjustment status of the scanning head.

- High resistance to contamination
- Defined thermal behavior of the DOUBLEFLEX scale tapes
- Mechanical isolation of the DOUBLEFLEX scale tapes
- Simple mounting of the self-adhesive scale tapes

## Areas of application

- Production and inspection machines for the semiconductor industry
- Linear units and drives
- Coordinate tables
- Measuring machines and measuring microscopes

- Robotics
- Precision devices for reprography
- Precision machining
- Positioning and measuring devices for medical technology

## Offset and Amplitude Control, Set up LED

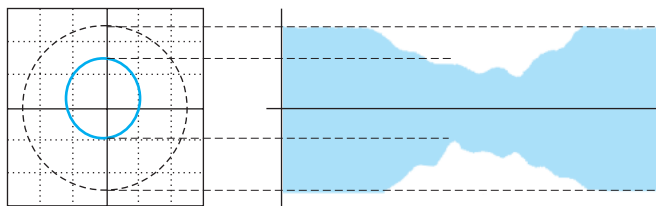
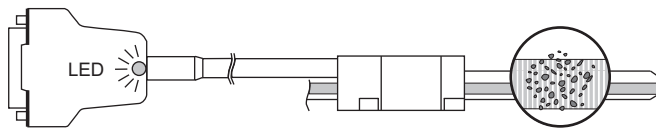

Scanning signal of **contaminated scale before** offset and amplitude correction

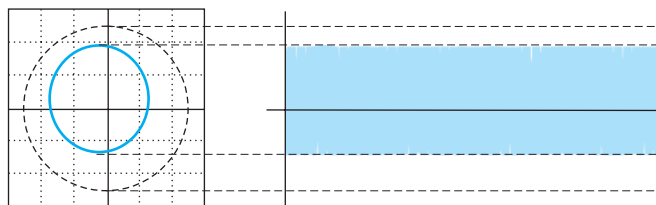
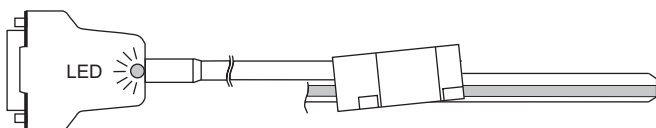

Scanning signal at **incorrect mounting conditions before** offset and amplitude correction

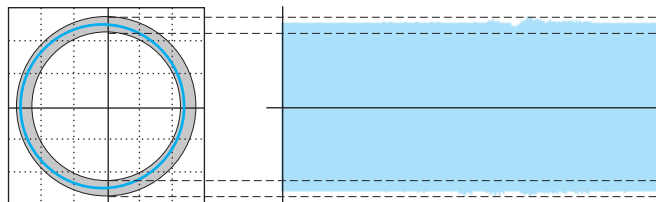

Scanning signal of **contaminated scale and/or incorrect mounting conditions after** offset and amplitude correction

### Dynamic Offset and Amplitude Control

Contamination and mounting errors lead to interferences in the optical scanning of the scale by the scanning head, and so to periodic deformations of the sinusoidal counting track signals.

These deformations manifest themselves as

- offset deviations and
- amplitude deviations, as well as
- amplitude differences between the sine and cosine channel

and lead to interpolation errors.

The signals generated by the measuring module are automatically corrected within the sensor without following error over the entire velocity range.

This measure not only increases the accuracy, but also the reliability of the encoder.

### Set up LED

The mechanical alignment of the scale and scanning head to each other can be checked with the set up LED.

The signal for triggering the LED is gained from the coarse sensor signals before the offset and amplitude control.

### Signaling of mounting errors

- The LED is dark when the encoder is optimally mounted according to the prescribed tolerances.
- The LED begins to shine when deviations from the optimal mounting state occur. The larger the deviations, the brighter the LED shines.

### Signaling of scale tape contaminations

- The LED lights up briefly when contaminated positions of the scale are traversed.

## Switch sensors

The opto-electronic switch sensors additionally integrated in the scanning head can be used

- to detect limit positions with left/right recognition **or**
- to indicate the scanning head position within the measuring range **or**
- to enable a reference mark (selection of **one** reference mark from **n** marks).

A combination of these variants is also possible.

By using these switch sensors, you save the cost and cabling for additional sensors.

The scanning head of the **LIA 21** is equipped with **one** switch sensor, and the scanning head of the **LIA 22** with **two** switch sensors.

The switch sensors of the LIA 22 can be differently aligned as viewed from the measuring direction (see page 7):

- S1 + S2 alignment behind each other in one track **or**
- S1 + S3 alignment next to each other in two parallel tracks

The switch sensors can be used universally via the various output circuits (ordering options):

- TTL low activ **or** TTL high activ
- open collector low activ **or** open collector high activ
- MOS relays opening **or** closing up to a 300 V switching voltage

When using MOS relays and two switch sensors (LIA 22), the two switching outputs have a common switching contact, which can be connected to either 0 V or to the switching voltage.

## Shown with DOUBLEFLEX scale tape

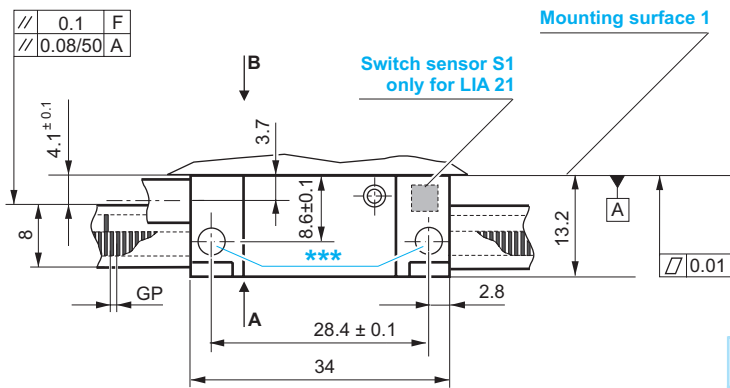
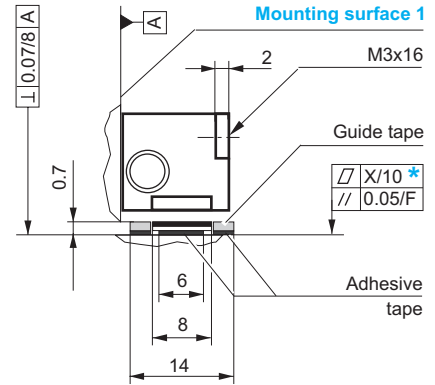
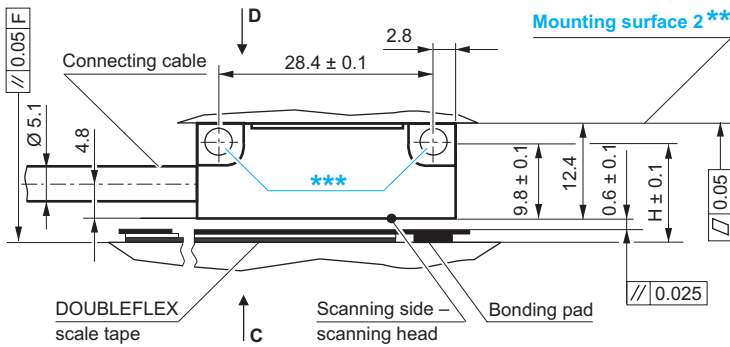

*	Deviation X per 10 mm of scale tape length (see table)
**	The mounting surface 2 must be vertically adjustable to ensure that the distance parameter $0.6 \pm 0.1$ and the parallelism $0.025$ can be achieved.
***	$\varnothing 3.6$ when M3-screws put from side A or C, M4-6H when screws put from side B or D

	H	Accuracy class	X
DOUBLEFLEX scale tape	11.1 mm	$\pm 1 \mu\text{m}$ $\pm 2 \mu\text{m}$	0.003 0.006
SINGLEFLEX scale tape	10.9 mm	$\pm 3 \mu\text{m}$ $\pm 5 \mu\text{m}$	0.009 0.009

F = machine guideway

## Definition of measuring length

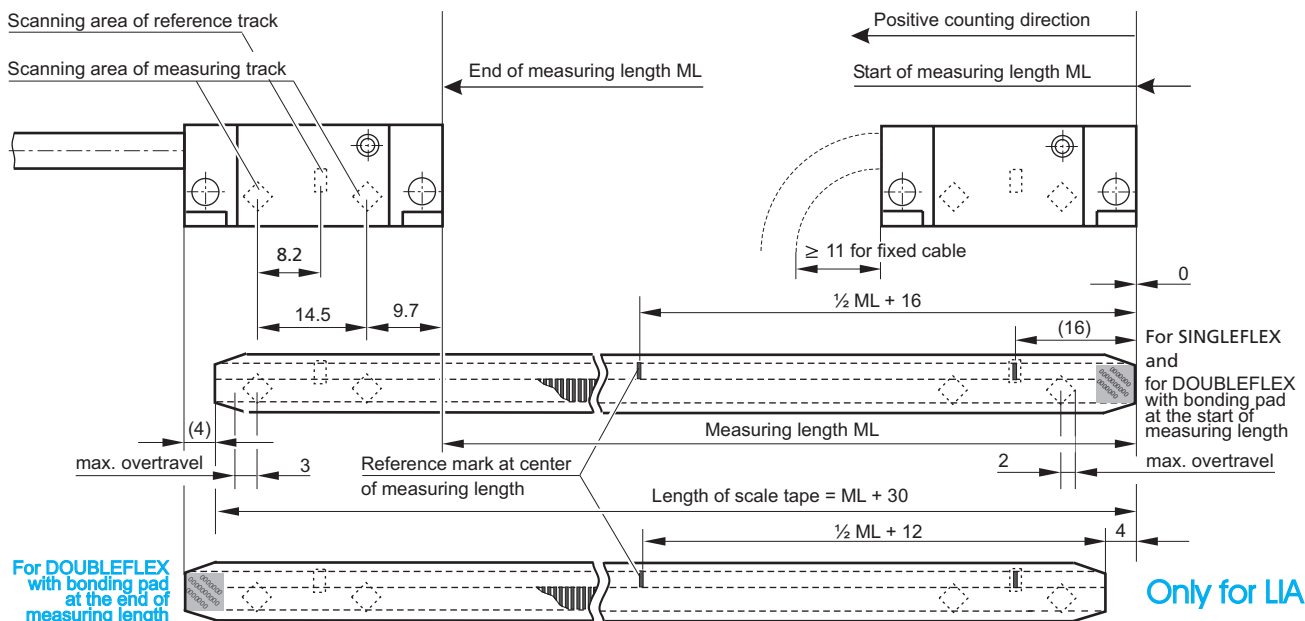

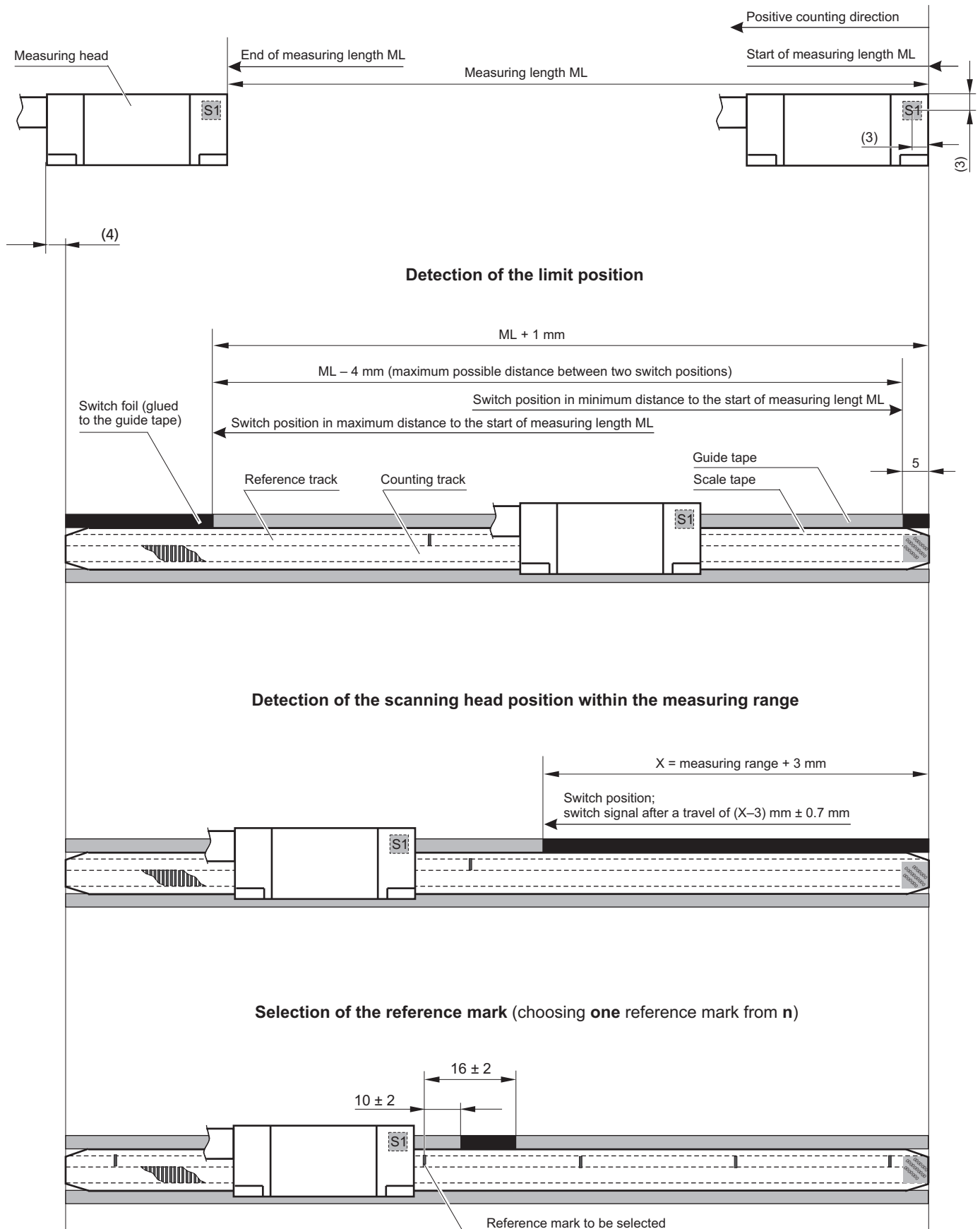

Shown with **DOUBLEFLEX** scale tape and guide tapes

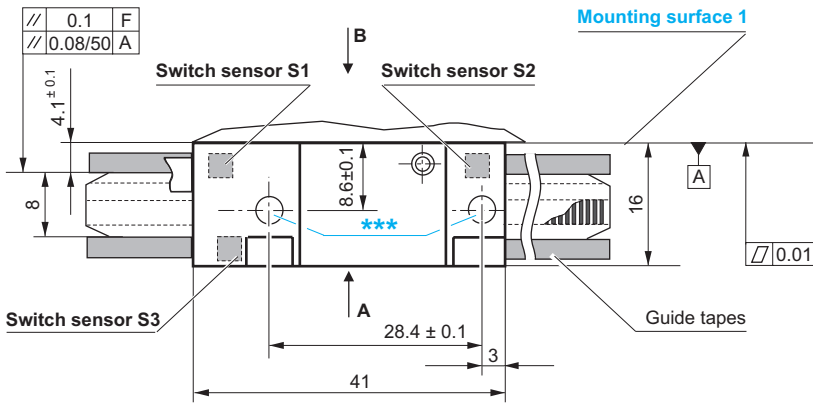
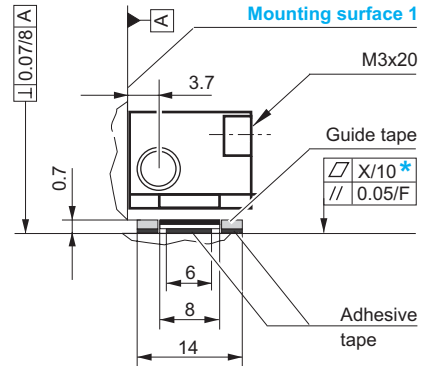
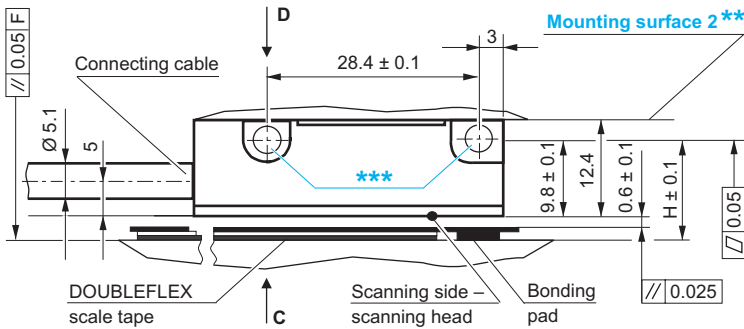

*	Deviation X per 10 mm of scale tape length (see table)
**	The mounting surface 2 must be vertically adjustable to ensure that the distance parameter $0.6 \pm 0.1$ and the parallelism $0.025$ can be achieved.
***	$\varnothing 3,6$ when M3-screws put from side A <b>and</b> $\varnothing 2,7$ when M2.5-screws put from side C <b>or</b> M4-6H when screws put from side B or D

  

	H	Accuracy class	X
DOUBLEFLEX scale tape	11.1 mm	$\pm 1 \mu\text{m}$ $\pm 2 \mu\text{m}$	0.003 0.006
SINGLEFLEX scale tape	10.9 mm	$\pm 3 \mu\text{m}$ $\pm 5 \mu\text{m}$	0.009 0.009

F = machine guideway

## Definition of measuring length

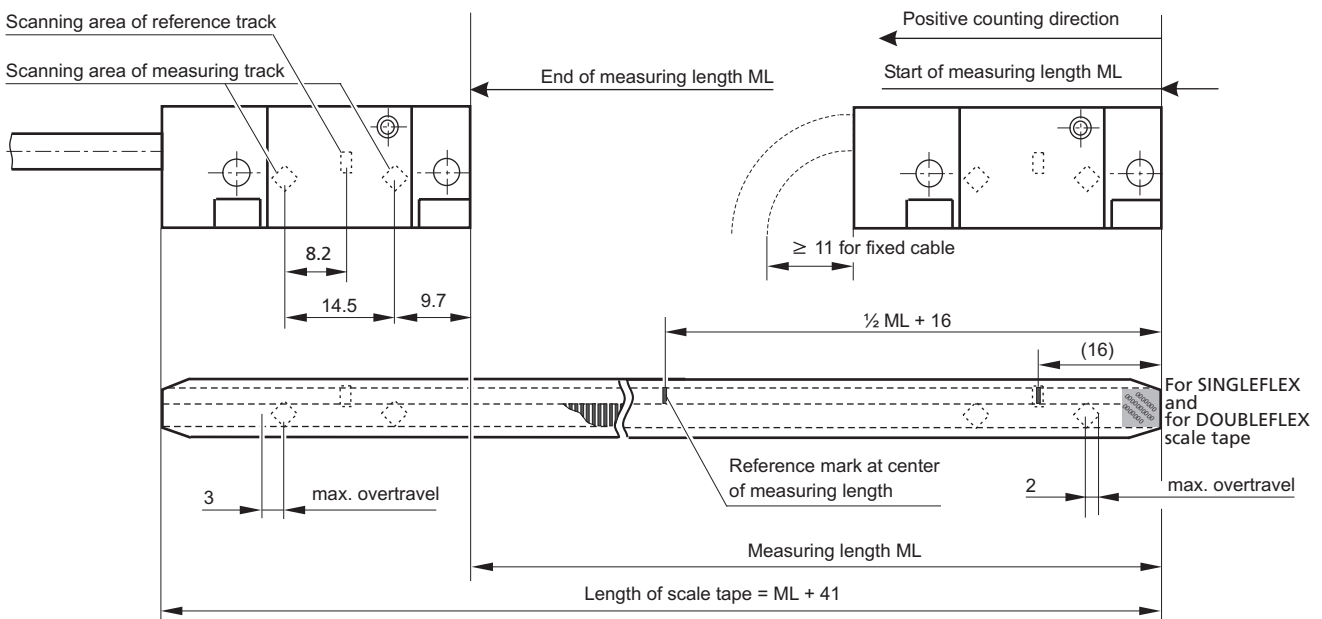

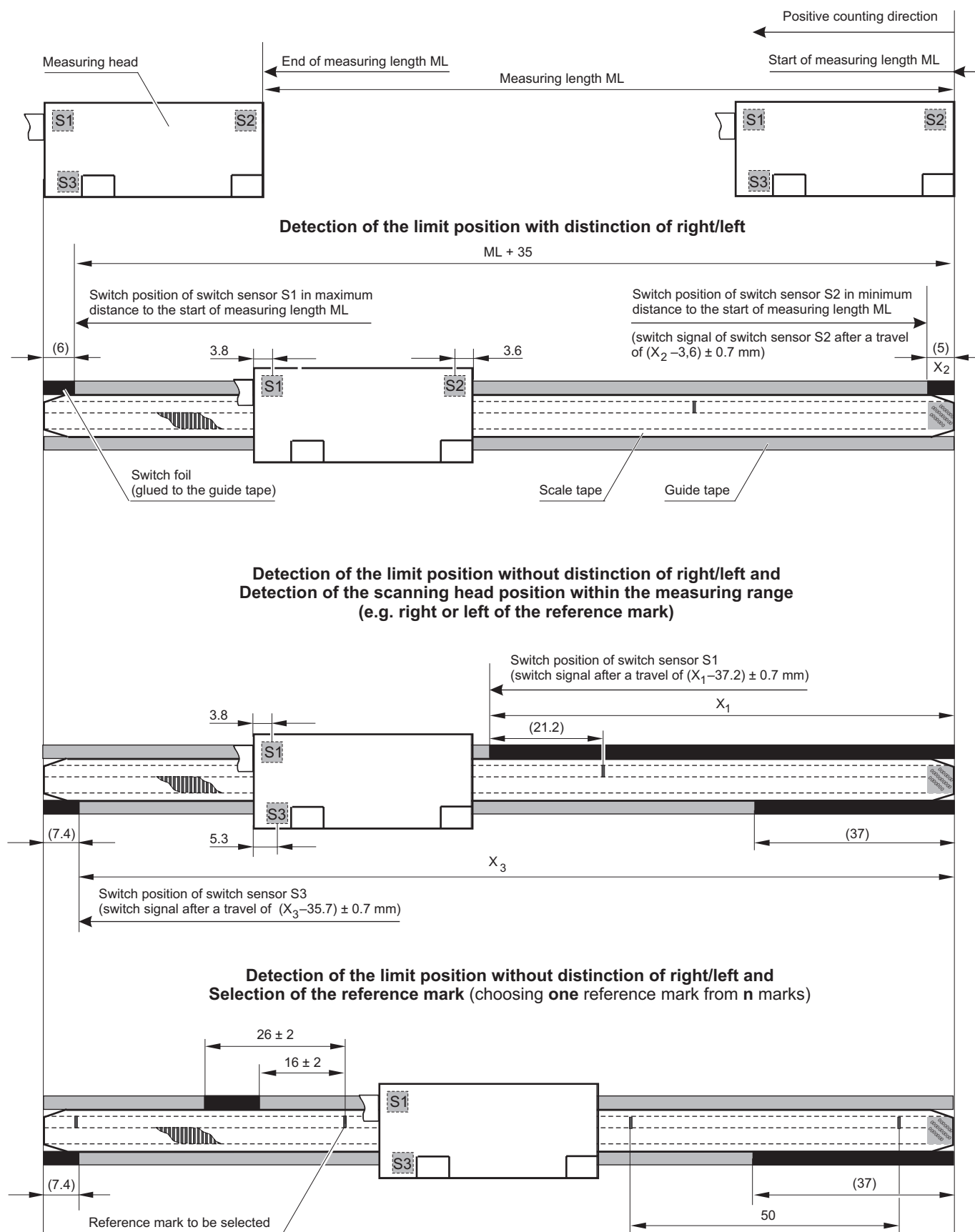

For DOUBLEFLEX scale tapes all versions are possible too, if bonding pad is at the end of measuring length.

# Connectors and PIN Layouts

## LIA 20 – 15-pin D-sub connector

PIN	1	2	3	4	5	6	7	8	9	10	11	12	13	14	15	Housing
1 V <sub>PP</sub>	–	–	–	U <sub>0–</sub>	U <sub>2–</sub>	U <sub>1–</sub>	5 V	5 V	0 V	–	–	U <sub>0+</sub>	U <sub>2+</sub>	U <sub>1+</sub>	–	Shield
RS 422	–	–	NAS	Z <sub>0–</sub>	Z <sub>2–</sub>	Z <sub>1–</sub>	5 V	5 V	0 V	–	AS	Z <sub>0+</sub>	Z <sub>2+</sub>	Z <sub>1+</sub>	–	Shield
Cable Ø 5.1 mm	–	–	violet	pink	red	yellow	brown	brown	white	–	black	grey	blue	green	–	–
Cable Ø 3.7 mm	–	–	violet	pink	red	brown	blue	blue	white	–	yellow	grey	black	green	–	–

## LIA 20 – 9-pin D-sub connector

PIN	1	2	3	4	5	6	7	8	9	Housing
1 V <sub>PP</sub>	U <sub>1–</sub>	0 V	U <sub>2–</sub>	–	U <sub>0–</sub>	U <sub>1+</sub>	5 V	U <sub>2+</sub>	U <sub>0+</sub>	Shield
RS 422	Z <sub>1–</sub>	0 V	Z <sub>2–</sub>	NAS	Z <sub>0–</sub>	Z <sub>1+</sub>	5 V	Z <sub>2+</sub>	Z <sub>0+</sub>	Shield
Cable Ø 5.1 mm	yellow	white	red	violet	pink	green	brown	blue	grey	–
Cable Ø 3.7 mm	brown	white	red	violet	pink	green	blue	black	grey	–

## LIA 20 – 12-pin circular connector (diameter 28; M 23 x 1)

PIN	1	2	3	4	5	6	7	8	9	10	11	12	Housing
1 V <sub>PP</sub>	U <sub>2–</sub>	5 V	U <sub>0+</sub>	U <sub>0–</sub>	U <sub>1+</sub>	U <sub>1–</sub>	–	U <sub>2+</sub>	–	0 V	0 V	5 V	Shield
RS 422	Z <sub>2–</sub>	5 V	Z <sub>0+</sub>	Z <sub>0–</sub>	Z <sub>1+</sub>	Z <sub>1–</sub>	NAS	Z <sub>2+</sub>	–	0 V	0 V	5 V	Shield
Cable Ø 5.1 mm	red	brown	grey	pink	green	yellow	violet	blue	–	white	white	brown	–
Cable Ø 3.7 mm	red	brown	grey	pink	green	brown	violet	black	–	white	white	blue	–

## LIA 21 – 15-pin D-sub connector

PINs 2 and 12 bridged, PINs 10 and 11 bridged

PIN	1	2	3	4	5	6	7	8	9	10	11	12	13	14	15	Housing
1 V <sub>PP</sub>	–	–	–	U <sub>0–</sub>	U <sub>2–</sub>	U <sub>1–</sub>	–	5 V	0 V	S1	–	U <sub>0+</sub>	U <sub>2+</sub>	U <sub>1+</sub>	–	Shield
RS 422	–	–	NAS	Z <sub>0–</sub>	Z <sub>2–</sub>	Z <sub>1–</sub>	–	5 V	0 V	S1	AS	Z <sub>0+</sub>	Z <sub>2+</sub>	Z <sub>1+</sub>	–	Shield
Cable Ø 5.1 mm	–	–	violet	pink	red	yellow	–	brown	white	–	black	grey	blue	green	–	–

For switch sensors with **TTL-** or **Open collector output**:  
S1 connected with PIN 10

For switch sensors with **TTL-** or **Relays output**:  
S1 connected with PIN 7 and PIN 10

## LIA 22 – 15-pin D-sub connector

PIN	1	2	3	4	5	6	7	8	9	10	11	12	13	14	15	Housing
1 V <sub>PP</sub>	–	S1	–	U <sub>0–</sub>	U <sub>2–</sub>	U <sub>1–</sub>	–	5 V	0 V	S2/S3	–	U <sub>0+</sub>	U <sub>2+</sub>	U <sub>1+</sub>	–	Shield
RS 422	–	S1	NAS	Z <sub>0–</sub>	Z <sub>2–</sub>	Z <sub>1–</sub>	–	5 V	0 V	S2/S3	AS	Z <sub>0+</sub>	Z <sub>2+</sub>	Z <sub>1+</sub>	–	Shield
Cable Ø 5.1 mm	–	–	violet	pink	red	yellow	–	brown	white	–	black	grey	blue	green	–	–

For switch sensors with **TTL-** or **Open collector output**:  
S1 connected with PIN 2  
S2 or S3 connected with PIN 10

For switch sensors with **Relays output**  
and **RS 422 without interpolation** or **1 V<sub>PP</sub>**:  
S1 connected with PIN 1 and PIN 2  
S2 or S3 connected with PIN 7 and PIN 10

For switch sensors with **Relays output**  
and **RS 422 with interpolation**:  
S1 connected with PIN 7 and PIN 2  
S2 or S3 connected with PIN 7 and PIN 10

# Technical Specifications

LIA Series	LIA 20	LIA 21	LIA 22
------------	--------	--------	--------





## Mechanical Data – Encoder

Dimensions of scanning head [mm]	34 x 13.2 x 12.4	34 x 13.2 x 12.4	41 x 16 x 12.4
Weight of scanning head without cable	≤ 20 g	≤ 20 g	≤ 30 g
Number of switch sensors	–	1	2
Recommended measuring increments	0.05 µm    0.1 µm	0.2 µm    0.5 µm	1.0 µm    5.0 µm
Max. travel speed (depending on auxiliary electronic units)	<ul style="list-style-type: none"> <li>without interpolation: 600 m/min</li> <li>with interpolation 100x: 48 m/min</li> </ul>		

## Mechanical Data – Scale Tapes

Material	steel		
Grating period GP	20 µm standard		
Reference marks	<ul style="list-style-type: none"> <li>at 50 mm spacings, starting at center of measuring length</li> <li>distance coded at 1000 x GP</li> <li>in the center of measuring length</li> <li>others on request</li> </ul>		
Linear expansion coefficient <ul style="list-style-type: none"> <li>DOUBLEFLEX scale tape</li> <li>SINGLEFLEX scale tape</li> </ul>	$10.5 \times 10^{-6} \text{ grad}^{-1}$ at function of material of the mounting surface		
Accuracy classes <ul style="list-style-type: none"> <li>DOUBLEFLEX scale tape</li> <li>SINGLEFLEX scale tape</li> </ul>	*) for GP = 100 µm only these accuracy classes $\pm 1 \mu\text{m}; \quad \pm 2 \mu\text{m}; \quad \pm 3 \mu\text{m}^*; \quad \pm 5 \mu\text{m}^*$ $\pm 5 \mu\text{m}^*; \quad \text{others on request}$		
Repeatability of switching signal	–	0.1 mm	

## Electrical Data

Scanning frequency	max. 500 kHz																										
Output interfaces for counting signals <ul style="list-style-type: none"> <li>voltage output </li> <li>square wave output </li> </ul>	1 V <sub>PP</sub> with integrated line driver RS 422 with internal signal interpolation 5x, 10x, 25x, 50x, 100x in the connector or in the scanning head (only LIA 20)																										
Output interface for switching signals <ul style="list-style-type: none"> <li>square wave output </li> </ul>	–	<table border="1"> <tbody> <tr> <td rowspan="2">TTL</td> <td>low aktiv</td> <td>output voltage</td> <td>U<sub>out low</sub> ≤ 0.4 V</td> </tr> <tr> <td>high aktiv</td> <td></td> <td>U<sub>out high</sub> ≥ 2.4 V</td> </tr> <tr> <td rowspan="2">Open collector</td> <td>low aktiv</td> <td>output current</td> <td>I<sub>out high</sub> ≤ 1 mA</td> </tr> <tr> <td>high aktiv</td> <td>max. dissipation</td> <td>I<sub>out low</sub> ≤ –16 mA P<sub>max</sub> = 24 mW</td> </tr> <tr> <td rowspan="2">MOS relays</td> <td>open contact</td> <td>max. switching voltage</td> <td>U<sub>max</sub> = 300 V</td> </tr> <tr> <td>closed contact</td> <td>max. continuous current</td> <td>I<sub>max</sub> = 0.1 A</td> </tr> <tr> <td></td> <td></td> <td>max. dissipation</td> <td>P<sub>max</sub> = 300 mW</td> </tr> </tbody> </table>	TTL	low aktiv	output voltage	U <sub>out low</sub> ≤ 0.4 V	high aktiv		U <sub>out high</sub> ≥ 2.4 V	Open collector	low aktiv	output current	I <sub>out high</sub> ≤ 1 mA	high aktiv	max. dissipation	I <sub>out low</sub> ≤ –16 mA P <sub>max</sub> = 24 mW	MOS relays	open contact	max. switching voltage	U <sub>max</sub> = 300 V	closed contact	max. continuous current	I <sub>max</sub> = 0.1 A			max. dissipation	P <sub>max</sub> = 300 mW
TTL	low aktiv	output voltage		U <sub>out low</sub> ≤ 0.4 V																							
	high aktiv		U <sub>out high</sub> ≥ 2.4 V																								
Open collector	low aktiv	output current	I <sub>out high</sub> ≤ 1 mA																								
	high aktiv	max. dissipation	I <sub>out low</sub> ≤ –16 mA P <sub>max</sub> = 24 mW																								
MOS relays	open contact	max. switching voltage	U <sub>max</sub> = 300 V																								
	closed contact	max. continuous current	I <sub>max</sub> = 0.1 A																								
		max. dissipation	P <sub>max</sub> = 300 mW																								
Supply voltage	5 V ± 10%																										
Power consumption <ul style="list-style-type: none"> <li>voltage output </li> <li>square wave output </li> </ul>	< 60 mA < 200 mA	< 70 mA < 210 mA	< 90 mA < 230 mA																								
Cable lengths Cable permanently connected to the scanning head Permissible total cable lengths with extension cable	up to 3 m (standard length: 0.3 m; 0.5 m; 1.0 m; 2.0 m; 3.0 m) 100 m for 1V <sub>PP</sub> und RS 422																										
Permissible bending radius	<ul style="list-style-type: none"> <li>occasional flexing</li> <li>constant flexing</li> </ul>	8 mm (cable 3.7) 40 mm (cable 3.7)	10 mm (cable 5.1) 50 mm (cable 5.1)																								

## Ambient Conditions

Operating temperature range	0°C ... +55°C
Storage temperature range	–20°C ... +70°C
Vibration (50 Hz ... 2000 Hz)	≤ 200 ms <sup>-2</sup>
Shock (11 ms)	≤ 400 ms <sup>-2</sup>
Humidity	93% RH (no condensing)

# Scale Tapes

## DOUBLEFLEX scale tape – always with bonding pad

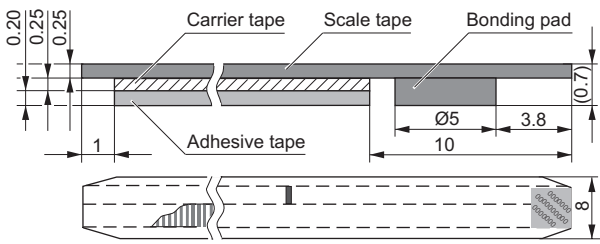

Mechanical isolation of the scale tape from the scale tape carrier; this results in defined thermal behavior.

### Preferentially used for:

- Carrier materials with thermal expansion behavior different from steel
- Measuring lengths from 100 mm
- High accuracy requirements

## SINGLEFLEX scale tape – always without bonding pad

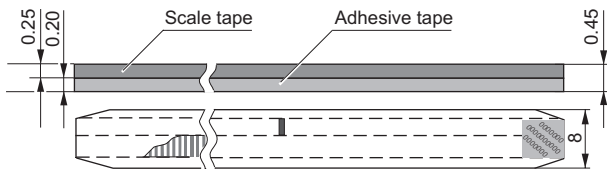

### Preferentially used for:

- Scale tape carrier with thermal expansion behavior same as steel ( $\alpha \approx 10,5 \times 10^{-6} \text{ grd}^{-1}$ )
- Low accuracy requirements

## Scale tape with guide tapes

Guide tapes are suitable for both DOUBLEFLEX and SINGLEFLEX scale tapes.

For encoders with switch sensors at least one guide tape is necessary, since the black switching foil for the switch sensors is glued onto the guide tape.

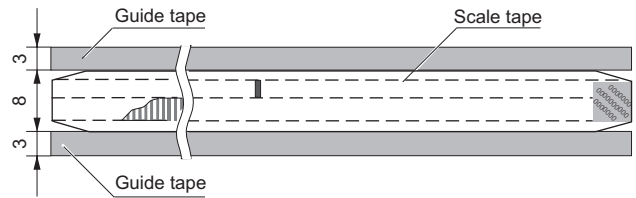

## Guide tape mounting device

The guide tape is applied to the mounting surface using the guide tape mounting device (FAV) as described in the mounting instructions.

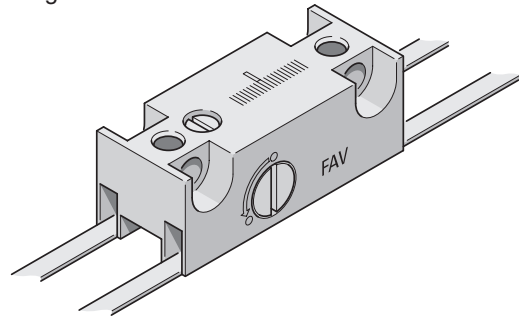

# Ordering Key – Scale Tapes

(Designation example)

MV	8	2	-	1	1	B	P	00770
----	---	---	---	---	---	---	---	-------

### Material

5	steel tape for LIA 20 steel tape for LIA 21
8	steel tape for LIA 22

### Design type

0	DOUBLEFLEX, standard
1	SINGLEFLEX, standard
2	DOUBLEFLEX with guide tape
3	SINGLEFLEX with guide tape

### Accuracy class

1	$\pm 1 \mu\text{m}$
2	$\pm 2 \mu\text{m}$
3	$\pm 3 \mu\text{m}$
4	$\pm 5 \mu\text{m}$

### Bonding pad position

0	without bonding pad <sup>2</sup>
1	at start of measuring length <sup>3</sup>
5 <sup>1</sup>	at end of measuring length <sup>3,4</sup>

measuring length (ML) [mm]

Grating period GP

P 20  $\mu\text{m}$

Position of reference mark

O	none
B	in the center of measuring length
E <sup>1</sup>	customized version
F	distance coded at 1000 x TP
N	at 50 mm spacings, starting at center of measuring length

**1** no standard,  
supplied with surcharge

**2** only for SINGLEFLEX scale tape

**3** only for DOUBLEFLEX scale tape

**4** only for LIA 20 and LIA 22

# Ordering Key – Scanning Head

(Designation example)

LIA 2 2 - P 4 2 1 - F Z

## Type of sensor

2	two-field – SV3 – R
---	---------------------

## Number of switch sensors

0	none
1	1 switch sensor
2	2 switch sensors

## Grating period

-	GP = 20 µm
---	------------

## Output signals

C	sinusoidal 1 V <sub>PP</sub>
K	RS 422 square wave signal without interpolation
L	RS 422 square wave signal with interpolation 5x
M	RS 422 square wave signal with interpolation 10x
I	RS 422 square wave signal with interpolation 25x
N	RS 422 square wave signal with interpolation 50x
P	RS 422 square wave signal with interpolation 100x

## Speed factor

X	Customer-specific value, depending on the max. speed and max. input frequency of the evaluation electronics; consult NUMERIK JENA
---	---

## Interface – switch sensors – LIA 20

0	without switch sensor
---	-----------------------

## Interface – switch sensors – LIA 21

1	one sensor – TTL – low active
5	one sensor – TTL – high active
A	one sensor – open collector – low active
D	one sensor – open collector – high active
G	one sensor – MOS relays – opening
H	one sensor – MOS relays – closing

## Interface – switch sensors – LIA 22

2	two sensors in line – TTL – low active
3	two sensors parallel – TTL – low active
6	two sensors in line – TTL – high active
7	two sensors parallel – TTL – high active
B	two sensors in line – open collector – low active
C	two sensors parallel – open collector – low active
E	two sensors in line – open collector – high active
F	two sensors parallel – open collector – high active
K	two sensors in line – MOS relays – opening
L	two sensors in line – MOS relays – closing
M	two sensors parallel – MOS relays – opening
N	two sensors parallel – MOS relays – closing

## Type of connector

A <sup>2</sup>	open; with 10-pin JST- test connector
D <sup>2</sup>	9-pin; D-sub; PIN; straight
H <sup>2</sup>	12-pin; circular; PIN; plastic-coated
O <sup>2</sup>	15-pin; D-sub; PIN; straight
S <sup>2</sup>	customized plug on request <sup>1</sup>
Z	15-pin; D-sub; electronic in the connector

## Type of cable

Cable Ø 5.1 mm <sup>5, 6</sup>		Cable Ø 3.7 mm <sup>2, 7</sup>	
A	0.3 m	R	0.3 m
B	0.5 m	S	0.5 m
F	1.0 m	T	1.0 m
E	1.5 m	P	1.5 m
G	2.0 m	V	2.0 m
K	3.0 m	W	3.0 m
O <sup>1</sup>	others on request	U <sup>1</sup>	others on request

## Version

-	standard (without set up LED)
3 <sup>1</sup>	without set up LED, non magnetic scanning head
K <sup>1, 3</sup>	with set up LED
N <sup>1, 3</sup>	with set up LED, non magnetic scanning head

## Installation conditions

1 <sup>4</sup>	bore Ø 3,6 in the scanning head
2	thread M4 in the scanning head

- no standard, supplied for a surcharge
- only for LIA 20
- only for RS 422 with interpolation in the connector
- LIA 22:  
Ø 3.6 for M3 screws from side A **and**  
Ø 2.7 for M2.5 screws from side C
- double shielded cable for LIA 21 and for LIA 22 and for LIA 20 with interpolation in the connector
- single shielded cable for LIA 20 with interpolation in the scanning head
- single shielded cable (only for LIA 20 all versions)

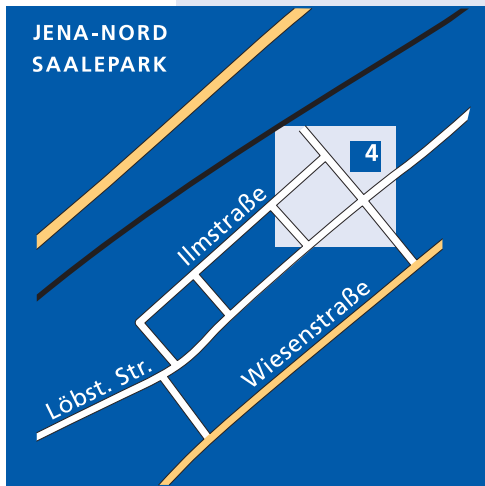

**NUMERIK JENA GmbH**  
 Ilmstraße 4  
 D-07743 Jena  
 Germany  
 Telephone ++49 3641 47 28 21  
 Fax ++49 3641 47 28 20  
 E-mail info@numerikjena.de  
 Internet www.numerikjena.de